

REGGIMENSOLE A PARETE

WALL FASTENER SYSTEMS

Zipp 2

Zipp 2

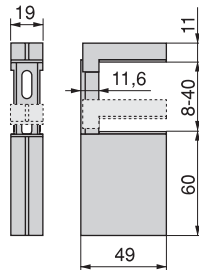

Cod.



62615 25 40

Tecnoplastica e zama
Plastic and zamak

- Secondo norma UNE EN-14749:2006 (mobili contenitori di uso domestico ed in cucine).
- Complies with UNE EN-14749:2006 (furniture for home and use kitchen).



- A-Fare un foro nel muro e inserire il tassello.
B-Fissare il supporto a parete mediante la vite 2 senza dimenticare la cremaliera 3. Non fissare molto forte per permettere la regolazione.
C-Regolare il supporto facendolo scorrere sulla cremaliera e avvitare definitivamente la vite 2.
D-Inserire la mensola nel supporto e bloccarlo mediante la vite 1.

- A-Drill wall and insert rawplugs.
B-Fix support to wall using screw 2 not forgetting ratchet piece 3. Do not screw too tight so that the level can be adjusted.
C-Level the supports by means of the ratchet 3 and then tighten screw 2.
D-Place the shelf on the supports and fasten using screw 1.

Zipp 3

Zipp 3

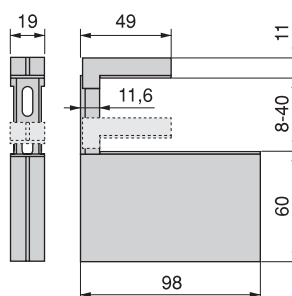

Cod.



63486 25 40

Tecnoplastica e zama
Plastic and zamak

- Dispone di una vite nella parte anteriore per la regolazione dell'inclinazione della mensola.
- Secondo norma UNE EN-14749:2006 (mobili contenitori di uso domestico ed in cucine).
- Has a screw on the front to adjust the shelf slope.
- Complies with UNE EN-14749:2006 (furniture for home and use kitchen).



- A-Fare un foro nel muro e inserire il tassello.
B-Fissare il supporto a parete mediante la vite 2 senza dimenticare la cremaliera 3. Non fissare molto forte per permettere la regolazione.
C-Regolare il supporto facendolo scorrere sulla cremaliera e avvitare definitivamente la vite 2.
D-Inserire la mensola nel supporto e bloccarlo mediante la vite 1.
E-Utilizzare la vite 4 per regolare la inclinazione della mensola.

- A-Drill wall and insert rawplugs.
B-Fix support to wall using screw 2 not forgetting ratchet piece 3. Do not screw too tight so that the level can be adjusted.
C-Level the supports by means of the ratchet 3 and then tighten screw 2.
D-Place shelf on the supports and fix in place with screw 1.
E-Use screw 4 to adjust the angle of the shelf.



Halcon

Halcon

Cod. 		
61930	24 25	40

Tecnoplastica e zama
 Plastic and zamak

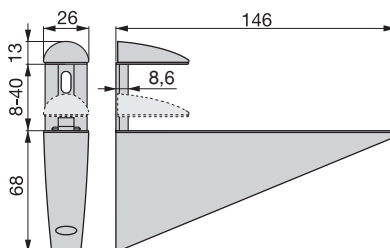

- Secondo norma UNE EN-14749:2006 (mobili contenitori di uso domestico ed in cucine).
- Complies with UNE EN-14749:2006 (furniture for home and use kitchen).



- A-Fare un foro nel muro e inserire il tassello.
 B-Fissare il supporto a parete mediante la vite 2 senza dimenticare la cremaliera 3. Non fissare molto forte per permettere la regolazione.
 C-Regolare il supporto facendolo scorrere sulla cremaliera e avvitare definitivamente la vite 2.
 D-Inserire la mensola nel supporto e bloccarlo mediante la vite 1.

- A-Drill wall and insert rawlplugs.
 B-Fix support to wall using screw 2 not forgetting ratchet piece 3. Do not screw too tight so that the level can be adjusted.
 C-Level the supports by means of the ratchet 3 and then tighten screw 2.
 D-Place shelf on the supports and fix in place with screw 1.



Venezia

Venecia

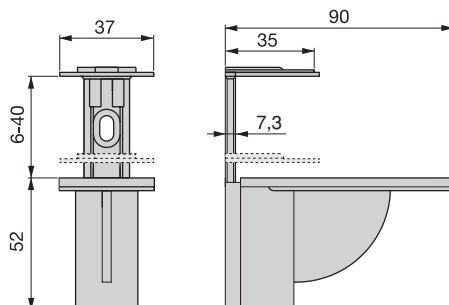

Cod.



86501 25 100

Tecnoplastica e zama
Plastic and zamak

- Due reggimensele poste a 400mm tra loro con una mensola da 600mm profonda 350mm e dello spessore di 40mm supportano un carico di 30Kg
- *The maximum weight the units support is 30Kg. Maximum shelf dimensions are 400mm wide, 350mm deep and 40mm thick.*



- A-Fare un foro nel muro e inserire il tassello.
B-Fissare il supporto a parete mediante la vite 2 senza dimenticare la cremaliera 3. Non fissare molto forte per permettere la regolazione.
C-Regolare il supporto facendolo scorrere sulla cremaliera e avvitare definitivamente la vite 2.
D-Inserire la mensola nel supporto e bloccarlo mediante la vite 1.

- A-Drill wall and insert rawlplugs.
B-Fix support to wall using screw 2 not forgetting ratchet piece 3. Do not screw too tight so that the level can be adjusted.
C-Level the supports by means of the ratchet 3 and then tighten screw 2.
D-Place the shelf on the supports and fasten using screw 1.*

Squad-2

Squad-2

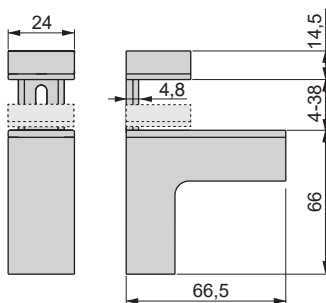

Cod.



60205 25 40

Tecnoplastica e zama
Plastic and zamak

- Secondo norma UNE EN-14749:2006 (mobili contenitori di uso domestico ed in cucine).
- *Complies with UNE EN-14749:2006 (furniture for home and use kitchen).*



- A-Fare un foro nel muro e inserire il tassello.
B-Fissare il supporto a parete mediante la vite 2 senza dimenticare la cremaliera 3. Non fissare molto forte per permettere la regolazione.
C-Regolare il supporto facendolo scorrere sulla cremaliera e avvitare definitivamente la vite 2.
D-Inserire la mensola nel supporto e bloccarlo mediante la vite 1.

- A-Drill wall and insert rawlplugs.
B-Fix support to wall using screw 2 not forgetting ratchet piece 3. Do not screw too tight so that the level can be adjusted.
C-Level the supports by means of the ratchet 3 and then tighten screw 2.
D-Place the shelf on the supports and fasten using screw 1.*



Mirlo

Mirlo

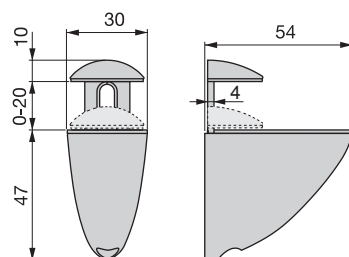

Cod.



62488	11	25	40
-------	----	----	----

Tecnoplastica e zama
Plastic and zamak

Azor

Azor

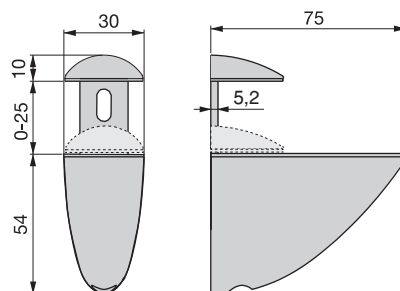

Cod.



62485	11	24	25	40
-------	----	----	----	----

Tecnoplastica e zama
Plastic and zamak

Pelicano

Pelicano

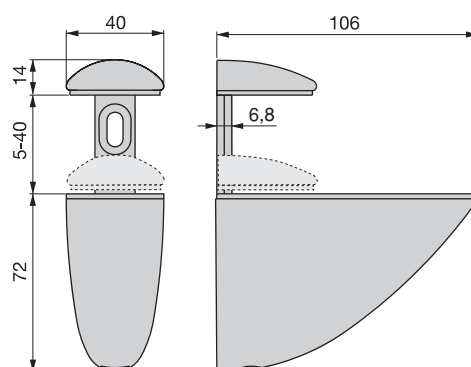

Cod.



51122	25	40
-------	----	----

Tecnoplastica e zama
Plastic and zamak

- Secondo norma UNE EN-14749:2006 (mobili contenitori di uso domestico ed in cucine).
- Complies with UNE EN-14749:2006 (furniture for home and use kitchen).



Mirlo / Azor / Pelicano



- A-Fare un foro nel muro e inserire il tassello.
B-Fissare il supporto a parete mediante la vite 2 senza dimenticare la cremaliera 3. Non fissare molto forte per permettere la regolazione.
C-Regolare il supporto facendolo scorrere sulla cremaliera e avvitare definitivamente la vite 2.
D-Inserire la mensola nel supporto e bloccarlo mediante la vite 1.

- A-Drill wall and insert rawlplugs.
B-Fix support to wall using screw 2 not forgetting ratchet piece 3. Do not screw too tight so that the level can be adjusted.
C-Level the supports by means of the ratchet 3 and then tighten screw 2.
D-Place the shelf on the supports and fasten using screw 1.

Reggimensola a scomparsa Phantom*Phantom hidden support*Cod. **69126** | **05** | 40

Acciaio / Steel

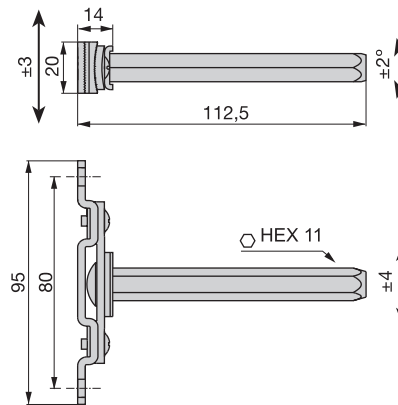

- Peso massimo per 2 reggimensole: 20kg per mensola da 900x300 mm 15kg per mensola da 900x350 mm.
- Per mensole superiori ai 900 mm, si raccomanda usare 3 reggimensole.
- Distanza massima tra reggimensole 700 mm.
- I tasselli non sono addatti per pareti in cartongesso.

- Max weight for 2 supports: 20kg for 900x300mm shelves 15kg for 900x350 mm shelves.
- For shelves longer than 900 mm, we recommend to use 3 supports.
- Max distance between supports 700 mm.
- The plugs supplied are not suitable for use with plasterboard walls.



Per un bloccaggio definitivo della mensola utilizzare l'eccentrico Ø15 Cod. 8006601 e relativo tirante 5137705 o 5137905.

For a better fixing of the shelf you can use Ø15 cam Cod. 8006601 and bolts 5137705 or 5137905.



MONTAGGIO:
ASSEMBLING:

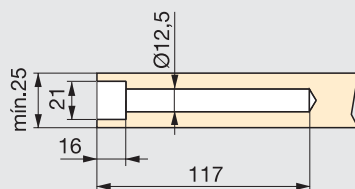

MONTAGGIO CON ECCENTRICO Ø15.
ASSEMBLING WITH Ø15 CAM..

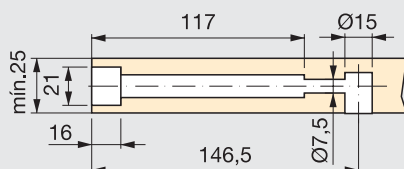

REGGIPENSILI PER MODULI ALTI

SUSPENDED HIGH MODULE HANGERS



Reggipensile Tack

Tack hanger



- Reggipensile a vista universale.
- Regolazione frontale.
- Visible hanger without side.
- Front adjustment.

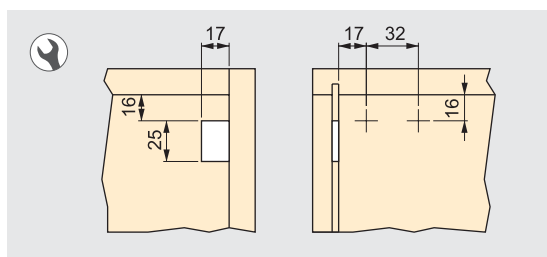
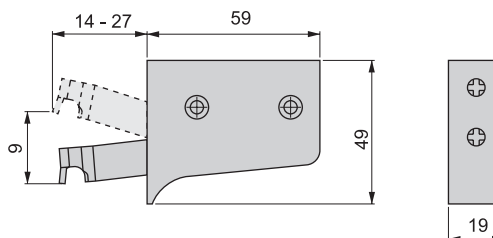

Descrizione Description	Cod.		
Per vite Screw-on	89227	21	200

Acciaio e tecnoplastica
Steel and plastic



Vite raccomandata
Ø3,5x30mm, Cod.5031706.

Recommend screw
Ø3,5x30mm, Cod.5031706.

Reggipensile Hook

Hook hanger



- Portata fino a 70 kg secondo norme UNI 10716.
- Regolazione frontale.
- Max. load 70 kg according to UNI 10716.
- Frontal adjustment.

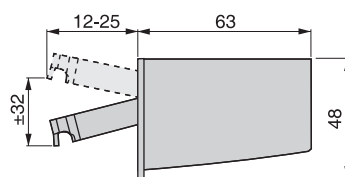

Descrizione Description	Lato Hand	Cod.		
Per vite Screw-on	Destra Right	89216	21	200
Per vite Screw-on	Sinistra Left	89215	21	200
A pressione Knock-in	Destra Right	89214	21	200
A pressione Knock-in	Sinistra Left	89213	21	200

Acciaio e tecnoplastica / Steel and plastic

MONTAGGIO HOOK A VITE SCREW-ON HOOK ASSEMBLY

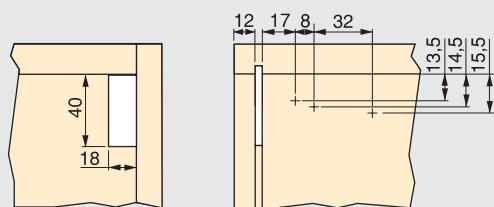

MONTAGGIO HOOK A PRESSIONE KNOCK-IN HOOK ASSEMBLY

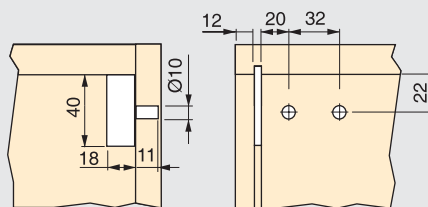

Vite raccomandata
Ø3,5x25.

We recommend screw
Ø3,5x25.

Tappi Hook

Hook covers



Lato / Hand	Cod.		
Destra / Right	89218	07 15 21	200
Sinistra / Left	89217	07 15 21	200

Tecnoplastica / Plastic

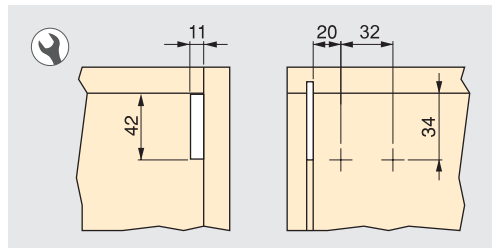
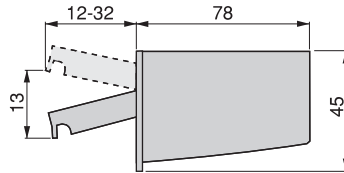
Reggipensile Holdy*Holdy hanger*

Descrizione Description	Lato Hand	Cod.		
Per vite Screw-on	Destra Right	43424	05	200
Per vite Screw-on	Sinistra Left	43425	05	200

Acciaio / Steel

Tappi Holdy*Holdy covers*

Lato / Hand	Cod.			
Destra / Right	43426	15	21	400
Sinistra / Left	43427	15	21	400

Tecnoplastica / Plastic

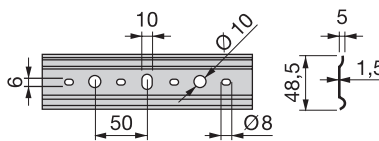
Barra reggipensile*Profile*

L	Cod.			
2 m	91733	05	10	

Acciaio / Steel

- La barra di acciaio si taglia facilmente senza necessità di utensili grazie alle sue piegature.

- The steel bar is easily cut without the need for tools thanks to its flexibility.

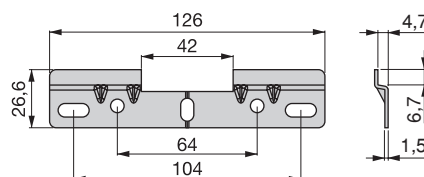
Piastra reggipensili*Mounting plate*

Cod.			
91732	05	400	

Acciaio / Steel



REGGIPENSILI NASCOSTI PER MODULI ALTI

HIDDEN HANGERS FOR UPPER CABINETS



- Per moduli da 600 mm a 1.000 mm di altezza e da 300 mm a 350 mm di profondità.
- 3 regolazioni: laterale 16 mm, in altezza fino a 18 mm e profondità fino a 25 mm.
- Capacità di carica 65kg per appendipensili secondo DIN-68840 certificato da LGA.
- Il fissaggio si realizza nel fianco del mobile indipendentemente dalla copertura superiore.
- Per un migliore fissaggio sono inclusi dei codoli metallici reversibili che si fissano al modulo mediante leva di bloccaggio.
- For kitchen cabinets between 600 mm and 1000 mm height and from 300 to 350 mm depth.
- It has 3 way adjustment: lateral 16 mm, height 18 mm and depth up to 25 mm.
- Load capacity 65kg each, according to DIN-68840 certified by LGA.
- It is fixed the side panel and is independent from the top panel.
- For a fast fixing it features a fixing lever, once this is operated the fitting is fixed.

Appendipensili Levelup

Levelup hanger

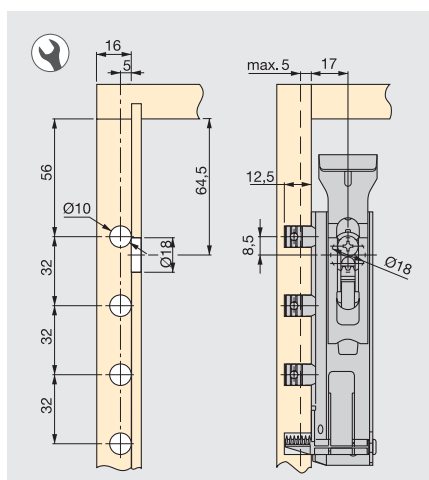
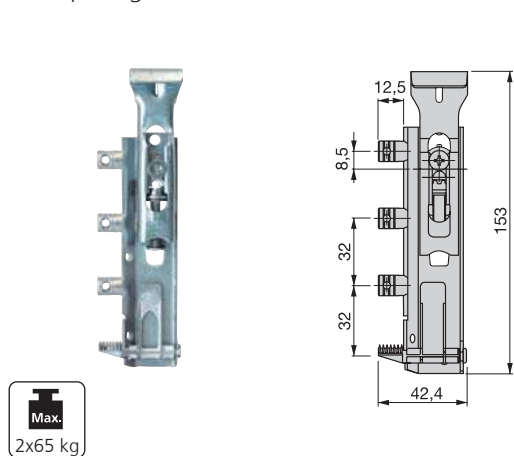

Lato Hand	Cod.		
Destra Right	89186	05	100
Sinistra Left	89187	05	100

Acciaio / Steel



Utilizzare cacciavite Philips n°2 Ø6 o Pozidrive n°2 Ø6.

Use screwdriver Philips n°2 Ø6 or Pozidrive n°2 Ø6

Piastrina doppia Levelup

Levelup double plate

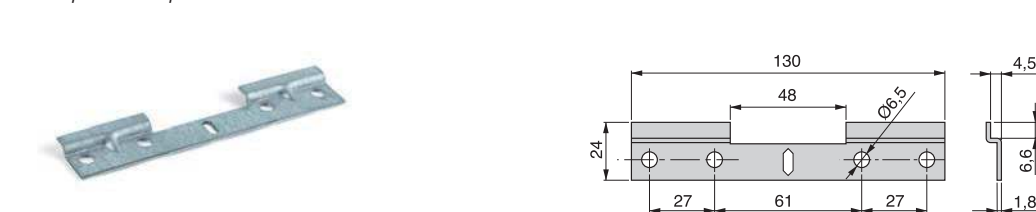

Cod.		
89188	03	200

Acciaio / Steel

Copriforo Levelup

Levelup cover

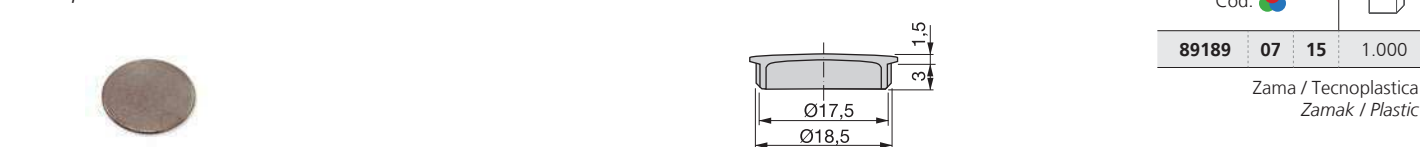

Cod.			
89189	07	15	1.000

Zama / Tecnoplastica
Zamak / Plastic

Set di appendipensili Levelup con piastrina

Set of Levelup hanger with plate



Cod.			
40086	05	1	

Acciaio / Steel



Ogni set contiene:
1 appendipensile mano destra.
1 appendipensile mano sinistra.
1 piastrina.

Each set contains:
1 hanger right hand.
1 hanger left hand.
1 plate.